

BXW(L/H/S) Models

Specifications

I BXW-□-□L (Braking use)

Model	Size	Static friction torque T_s [N·m]	Coil (at 20°C)				Heat resistance class	Lead wire		Max. rotation speed [min ⁻¹]	Rotating part moment of inertia J [kg·m ²]	Allowable braking energy rate P_{ba} [W]	Total braking energy E_t [J]	Armature pull-in time t_a [s]	Armature release time t_r [s]	Mass [kg]
			Voltage [V]	Wattage [W]	Current [A]	Resistance [Ω]		UL style	Size							
BXW-01-10L	01	0.12	12	5.0	0.417	28.8	F	UL3398	AWG26	5000	0.6×10^{-6}	2.5	1.5×10^6	0.008	0.015	0.2
			24	5.0	0.208	115	F									
			45	5.0	0.111	405	F									
			90	5.0	0.056	1622	F									
			180	5.0	0.028	6486	F									
BXW-02-10L BXW-02-12L	02	0.25	12	6.6	0.550	21.8	F	UL3398	AWG26	5000	1.9×10^{-6}	5.0	3.0×10^6	0.008	0.015	0.3
			24	6.6	0.275	87.3	F									
			45	6.6	0.147	307	F									
			90	6.6	0.073	1228	F									
			180	6.6	0.037	4912	F									
BXW-03-10L BXW-03-12L	03	0.50	12	9.0	0.750	16.0	F	UL3398	AWG26	5000	3.8×10^{-6}	10.0	4.5×10^6	0.025	0.025	0.4
			24	9.0	0.375	64.0	F									
			45	8.2	0.182	247	F									
			90	8.2	0.091	988	F									
			180	8.2	0.046	3954	F									
BXW-04-10L BXW-04-12L	04	1.00	12	11.5	0.958	12.5	F	UL3398	AWG22	5000	12.0×10^{-6}	20.0	7.0×10^6	0.030	0.030	0.6
			24	11.5	0.479	50.1	F									
			45	10.0	0.222	203	F									
			90	10.0	0.111	810	F									
			180	10.0	0.056	3241	F									
BXW-05-10L BXW-05-12L	05	2.00	12	13.0	1.083	11.1	F	UL3398	AWG22	5000	23.0×10^{-6}	30.0	12.0×10^6	0.035	0.035	0.8
			24	13.0	0.542	44.3	F									
			45	13.0	0.289	156	F									
			90	13.0	0.144	623	F									
			180	13.0	0.072	2492	F									

* Depending on the initial torque characteristics, break-in to condition the engaging surfaces may be required.

I BXW-□-□H (Holding use)

Model	Size	Static friction torque T_s [N·m]	Coil (at 20°C)				Heat resistance class	Lead wire		Max. rotation speed [min ⁻¹]	Rotating part moment of inertia J [kg·m ²]	Allowable braking energy rate P_{ba} [W]	Total braking energy E_t [J]	Armature pull-in time t_a [s]	Armature release time t_r [s]	Mass [kg]
			Voltage [V]	Wattage [W]	Current [A]	Resistance [Ω]		UL style	Size							
BXW-01-10H	01	0.24	12	5.0	0.417	28.8	F	UL3398	AWG26	5000	0.6×10^{-6}	0.5	0.2×10^6	0.010	0.010	0.2
			24	5.0	0.208	115	F									
			45	5.0	0.111	405	F									
			90	5.0	0.056	1622	F									
			180	5.0	0.028	6486	F									
BXW-02-10H BXW-02-12H	02	0.50	12	6.6	0.550	21.8	F	UL3398	AWG26	5000	1.9×10^{-6}	1.0	0.3×10^6	0.010	0.010	0.3
			24	6.6	0.275	87.3	F									
			45	6.6	0.147	307	F									
			90	6.6	0.073	1228	F									
			180	6.6	0.037	4912	F									
BXW-03-10H BXW-03-12H	03	1.00	12	9.0	0.750	16.0	F	UL3398	AWG26	5000	3.8×10^{-6}	2.0	0.5×10^6	0.035	0.020	0.4
			24	9.0	0.375	64.0	F									
			45	8.2	0.182	247	F									
			90	8.2	0.091	988	F									
			180	8.2	0.046	3954	F									
BXW-04-10H BXW-04-12H	04	2.00	12	11.5	0.958	12.5	F	UL3398	AWG22	5000	12.0×10^{-6}	4.0	1.0×10^6	0.040	0.025	0.6
			24	11.5	0.479	50.1	F									
			45	10.0	0.222	203	F									
			90	10.0	0.111	810	F									
			180	10.0	0.056	3241	F									
BXW-05-10H BXW-05-12H	05	4.00	12	13.0	1.083	11.1	F	UL3398	AWG22	5000	23.0×10^{-6}	6.0	2.0×10^6	0.045	0.030	0.8
			24	13.0	0.542	44.3	F									
			45	13.0	0.289	156	F									
			90	13.0	0.144	623	F									
			180	13.0	0.072	2492	F									

I BXW-□-□S (Dedicated for holding)

Model	Size	Static friction torque T_s [N·m]	Coil (at 20°C)				Heat resistance class	Lead wire		Max. rotation speed [min ⁻¹]	Rotating part moment of inertia J [kg·m ²]	Allowable braking energy rate P_{ba} [W]	Total braking energy E_t [J]	Armature pull-in time t_a [s]	Armature release time t_r [s]	Mass [kg]
			Voltage [V]	Wattage [W]	Current [A]	Resistance [Ω]		UL style	Size							
BXW-01-10S	01	0.36	24	5.0	0.208	115	F	UL3398	AWG26	5000	0.6×10^{-6}	—	—	0.025	0.010	0.2
BXW-02-10S BXW-02-12S	02	0.75	24	6.6	0.275	87.3	F	UL3398	AWG26	5000	1.9×10^{-6}	—	—	0.030	0.010	0.3
BXW-03-10S BXW-03-12S	03	1.50	24	9.0	0.375	64.0	F	UL3398	AWG26	5000	3.8×10^{-6}	—	—	0.035	0.020	0.4
BXW-04-10S BXW-04-12S	04	2.60	24	11.5	0.479	50.1	F	UL3398	AWG22	5000	12.0×10^{-6}	—	—	0.040	0.025	0.6
BXW-05-10S BXW-05-12S	05	5.20	24	13.0	0.542	44.3	F	UL3398	AWG22	5000	23.0×10^{-6}	—	—	0.045	0.030	0.8

* The armature pull-in time and armature release time are taken during DC switching.

Dimensions

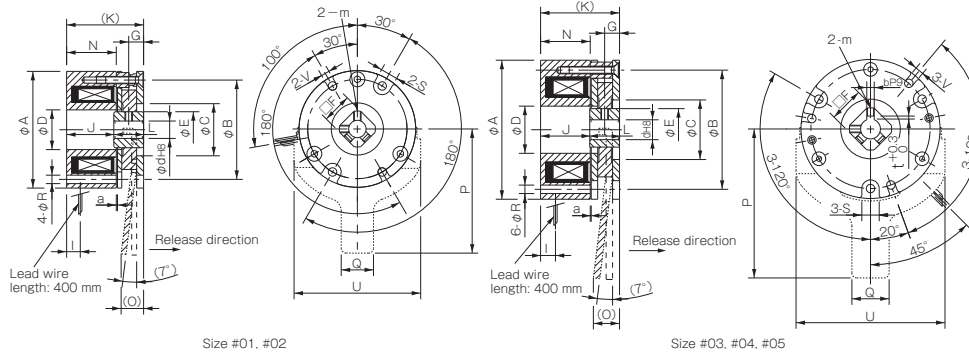

Unit [mm]

Size	Radial direction dimensions											Axial direction dimensions								Bore dimensions				
	A	B	C	D	E	S	V	R	F	m	O	P	Q	U	G	I	J	K	L	N	a	d	b	t
01	37	32	18	13.5	12.0	6	3	3	10	M3	-	-	-	-	4.5	5.0	22.5	31.5	9	22.5	0.10	5	-	-
02	47	40	21	16.0	14.5	7	3.4	3.4	12	M3	9(10.2)	50	13	51	6.0	5.5	19.2	31.2	12	20.0	0.10	6	-	-
03	56	48	24	19.0	17.0	7	3.4	3.4	14	M3	11(11.7)	60	15	60	6.0	6.0	19.9	31.9	12	20.0	0.15	8	-	-
04	65	58	35	24.0	22.0	7	3.4	3.4	18	M4	12(12.5)	70	15	70	7.0	7.0	19.9	33.9	14	21.0	0.15	10	3	1.2
05	75	66	36	28.0	26.5	9	4.5	4.5	22	M4	14(14.5)	80	20	80	7.0	7.0	22.1	36.1	14	21.5	0.15	12	4	1.5

* There is no release lever option for size #01.

* The dimensions in parentheses () are values for BXW-□-□-□.

How to Place an Order

BXW-01-10L-24V-5

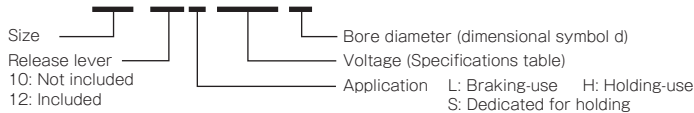

* Models equipped with the release lever and models with 12-V and 180-V voltage specifications are made to order.

* Contact Miki Pulley for assistance with bore diameters, d, not listed in the Dimensions tables and voltages not listed in the Specifications table.

Options Dust Cover

Dust covers are available as options. These enable use in challenging environments by keeping out foreign matter. Dust covers come in two types: full covers that have no hole for the shaft, and shaft-hole covers, which can be used on brakes mounted with the shaft passing through. You can also choose the locations of the lead exit holes for brakes mounted on plates or mounted on stators.



Specifications

Material	Ethylene propylene diene monomer (EPDM) rubber
Temperature range	-40°C to 140°C
Exterior color	Black
Applicable brake models	L type, H type, S type BXW models
Applicable brake sizes	#01, #02, #03, #04, #05
Applicable specification voltages	12 V DC, 24 V DC, 45 V DC, 90 V DC, 180 V DC

* This temperature range is for dust cover materials. The operating temperature for BXW models is -10°C to 40°C.

* Cannot be mounted on BXW models with release levers or R-type BXW models.

How to Place an Order

BXW-01-C02

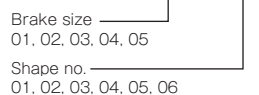

Dimensions

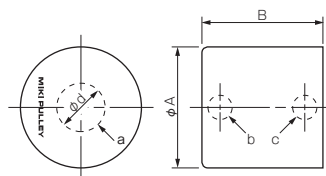

Shape No.	a	b	c
01	×	×	×
02	×	×	○
03	×	○	×
04	○	×	×
05	○	×	○
06	○	○	×

Unit [mm]

Model	φ A	B	φ d
BXW-01-C□	41	33	16
BXW-02-C□	51	33	21
BXW-03-C□	60	33.5	24
BXW-04-C□	69	35.5	30
BXW-05-C□	79	37.5	30

* Symbol a indicates a hole made for brakes with shafts passing through; symbol b indicates a hole made for lead exit when mounted on a plate; symbol c indicates a hole made for lead exit when mounted on a stator.

* Shapes #01 and #04 require that a hole be made separately for leads to exit.

BXW(R) Models

Specifications

Model	Size	Static friction torque T_s [N·m]	Coil (at 20°C)				Heat resistance class	Lead wire		Max. rotation speed [min ⁻¹]	Rotating part moment of inertia J [kg·m ²]	Allowable braking energy rate E_{ba} [J]	Total braking energy E_T [J]	Armature pull-in time t_a [s]	Armature release time t_r [s]	Mass [kg]
			Voltage [V]	Wattage [W]	Current [A]	Resistance [Ω]		UL style	Size							
BXW-01-10R	01	0.3	24	6.1	0.254	94.4	F	UL3398	AWG26	6000	1.36×10^{-7}	15	3000	0.035	0.020	0.1
BXW-03-10R	03	1.3	24	7.2	0.300	80.0	F	UL3398	AWG22	6000	1.17×10^{-6}	87	17000	0.050	0.020	0.3
BXW-05-10R	05	2.5	24	8.0	0.333	72.0	F	UL3398	AWG22	6000	3.68×10^{-6}	200	40000	0.060	0.020	0.5

* The armature pull-in time and armature release time are taken during DC switching.

Dimensions

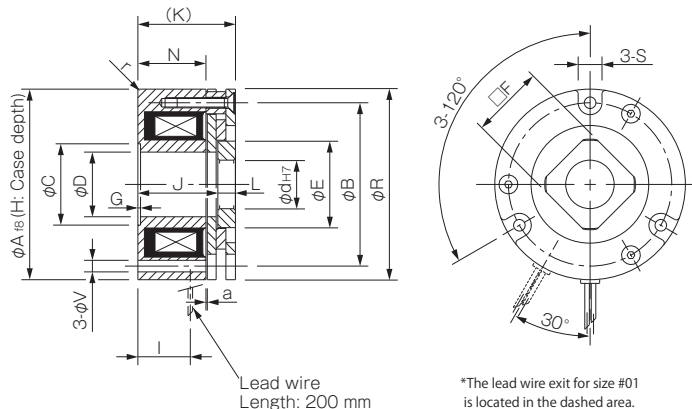

Size	Radial direction dimensions										Axial direction dimensions						Bore dimensions			
	A	r	B	C	D	E	S	V	R	F	G	H	I	J	K	L	N	a	d	d max
01	33	R0.5	26.5	16	9	14	7	3.4	32.5	12	0.2	4	19	25.5~26	30	4	22.8	0.1	8.5	8.5
03	48	R1	42	26	14	23	8	3.4	47.5	19	0.2	4	18	25.5~26	30	4	22.6	0.1	11	15
05	64	R1	56	28	22	31	8	4.5	63.5	25	0.2	4	16	25~25.5	30	4.5	21.3	0.1	16	20

* Bore diameters other than the standard bore diameters given above are also possible. d max indicates the maximum bore diameter with a round shaft.
 * In addition to round bores, key processing can also be handled. Consult Miki Pulley for details.
 * Dimensions, mounting and the like are not interchangeable with other BXW models.

How to Place an Order

BXW-01-10R-24V-8.5



*Contact Miki Pulley for assistance with bore diameters, d, not listed in the Dimensions tables and voltages not listed in the Specifications table.

BXW Models

Items Checked for Design Purposes

I Precautions for Handling

■ Brakes

Most electromagnetic braking systems are made using flexible materials. Be careful when handling such parts and materials as striking or dropping them or applying excessive force could cause them to become damaged or deformed.

■ Lead Wires

Be careful not to pull excessively on the brake lead wires, bend them at sharp angles, or allow them to hang too low.

■ Frictional Surface

Since these are dry brakes, they must be used with the frictional surface dry. Keep water and oil off of the frictional surfaces when handling the brakes.

I Precautions for Mounting

■ Mounting Orientation

BXW models can be mounted on either the stator or the plate. Select your mounting orientation as the application dictates. Be aware, however, that the BXW(R) type is only compatible with stator centering-mark mounting. Your understanding is appreciated.

■ Affixing the Rotor Hub

Affix the rotor hub to the shaft with hex-socket-head set screws such that the rotor hub does not touch the armature or stator. If you are applying adhesive to the hex-socket-head set screws, be careful that the adhesive does not come out onto the rotor hub surface. Note also that since the BXW(R) type is constructed so that the rotor hub does not go through the stator, affix it by press-fitting it onto the shaft at a position that does not touch the armature (see dimension J) when they are assembled.

■ Mounting the Brake

Implement screw-locking measures such as use of an adhesive thread-locking compound to bolts and screws used to install brakes. If using a spring washer to prevent loosening, use a conical spring washer, and ensure that it does not contact the armature.

■ Shafts

The shaft tolerance should be h7 class (JIS B 0401). Note that the harder the material used in the shaft, the less effective the hexagon-socket set screw will be. Note also that for the BXW(R) type, the shaft is press fitted into the rotor hub. We recommend that the shaft tolerance be a press-fit tolerance of r6 class (JIS B 0401).

■ Accuracy of Brake Attachment Surfaces

Make sure that concentricity (X) and perpendicularity (Y) do not exceed the allowable values of the table below.

Size	Concentricity (X) T.I.R. [mm]	Perpendicularity (Y) T.I.R. [mm]
01	0.05	0.02
02	0.05	0.02
03	0.10	0.02
04	0.10	0.02
05	0.10	0.02

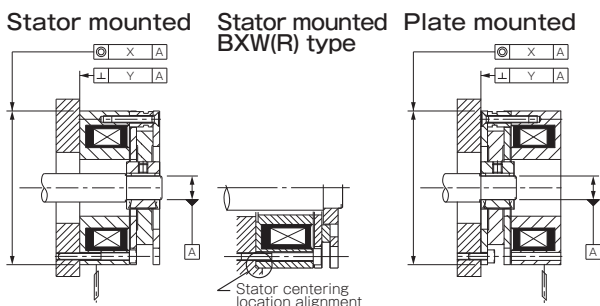

I Precautions for Use

■ Applications

This brake is available in braking, holding, and dedicated for holding types according to the application. Do not use BXW(H/R) types for ordinary braking, except for emergency braking in the event of a power outage or the like. You should note that BXW(S) types dedicated for holding cannot effect emergency braking in the event of a power outage.

Model (type)	Application	Braking: possible/not possible
BXW(L)	Braking use	Possible
BXW(H)	Holding use	Limited to emergency braking during power outage, etc.
BXW(S)	Dedicated for holding	Not possible
BXW(R)	Holding use	Limited to emergency braking during power outage, etc.

■ Environment

These brake units are dry braking systems, meaning that the torque will drop if oil residue, moisture, or other liquids get onto friction surfaces. In addition to friction surfaces, lead wires are not oil resistant. Lead wire covers may deteriorate noticeably in environments exposed to oil, cutting oil, etc.

■ Operating Temperature

The operating temperature range is -10° C to 40° C. If you will use the product at other temperatures, consult Miki Pulley.

■ Power Supplies

BXW models use commercial AC 100 V or 200 V single phase, full-wave rectified or half-wave rectified. Select as appropriate for your application. See the table below, "Recommended power supplies and circuit protectors," for the power supply devices we recommend.

■ Power Supply Voltage Fluctuations

Full braking performance may not be guaranteed with extreme changes in power supply voltage. Make sure to keep power supply voltage to within ± 10% of the rated voltage value.

■ Air Gap Adjustment

BXW models do not require air gap adjustment. The brake air gap is adjusted when the braking system is shipped from the factory.

■ Initial Torque

The torque may be lower than the indicated value at initial use. In such cases, run it to break in the frictional surface before use.

■ Circuit Protectors

If using a power supply that is not equipped with a circuit protector for DC switching, make sure to connect the recommended circuit protector device in parallel with the brake.

I Recommended Power Supplies and Circuit Protectors

Recommended power supplies

Input AC power	Brake voltage	Rectification method	Recommended power supply model
AC100V 50/60Hz	DC24V	Single-phase, full-wave	BES-20-71-1
AC100V 50/60Hz	DC45V	Single-phase, half-wave	BEW-1R
AC100V 50/60Hz	DC90V	Single-phase, full-wave	BEW-1R
AC200V 50/60Hz	DC24V	Single-phase, full-wave	BES-20-71
AC200V 50/60Hz	DC90V	Single-phase, half-wave	BEW-2R
AC200V 50/60Hz	DC180V	Single-phase, full-wave	BEW-2R
AC400V 50/60Hz	DC180V	Single-phase, half-wave	BEW-4R

* A DC power supply such as a battery can also be used to supply the 24 V DC required for the brake voltage.

Recommended circuit protectors

Input voltage	Brake voltage	Rectification method	Recommended circuit protector (varistor)
DC24V	DC24V	-	NVD07SCD082 or an equivalent
AC100V 50/60Hz	DC45V	Single-phase, half-wave	NVD07SCD220 or an equivalent
AC100V 50/60Hz	DC90V	Single-phase, full-wave	NVD07SCD220 or an equivalent
AC200V 50/60Hz	DC90V	Single-phase, half-wave	NVD07SCD470 or an equivalent
AC200V 50/60Hz	DC180V	Single-phase, full-wave	NVD07SCD470 or an equivalent
AC400V 50/60Hz	DC180V	Single-phase, half-wave	NVD14SCD820 or an equivalent

* NVD □ SCD □ parts are manufactured by KOA Corporation.

* DC24V indicates a product recommended with a stepdown transformer or the like.

* BXW models do not come with circuit protectors.

COUPLINGS

ETP BUSHINGS

ELECTROMAGNETIC CLUTCHES & BRAKES

SPEED CHANGERS & REDUCERS

INVERTERS

LINEAR SHAFT DRIVES

TORQUE LIMITERS

ROSTA

SERIES

ELECTROMAGNETIC-ACTUATED MICRO CLUTCHES & BRAKES

ELECTROMAGNETIC-ACTUATED CLUTCHES & BRAKES

ELECTROMAGNETIC CLUTCH & BRAKE UNITS

SPRING-ACTUATED BRAKE

ELECTROMAGNETIC TOOTH CLUTCHES

BRAKE MOTORS

POWER SUPPLIES

MODELS

BXW

BXR

BXL

BXH

BXL(IN)